

TECHNICAL INFORMATION



PRODUCT

P 1 / 11

Models No. ▶ SG1250

Description ▶ Wall chaser 125mm (5")

CONCEPT AND MAIN APPLICATIONS

Are you still employing chisel, when you groove for plumbing in the wall? Chisel is a past method! Grooving with model SG1250 is the new style of plumbing.

Its features and benefits are as follows.

- * Electronic for soft start, constant rotational speed
- * SJS (Super Joint System) for avoiding the shock by accidental wheel jam.
- * Precise grooving work with coaxial 2 diamond wheels

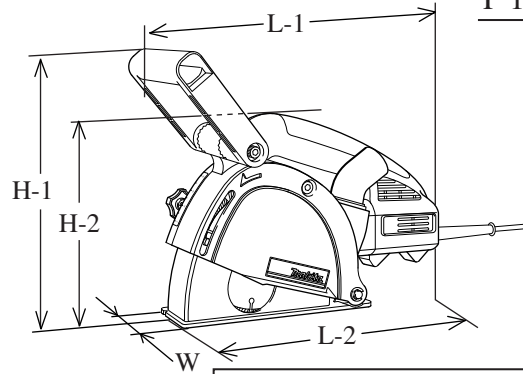

Dimensions : mm (")	
Length (L-1)	376 (14-3/4)
Length (L-2)	346 (13-5/8)
Width (W)	151 (5-15/16)
Height (H-1)	284 (11-1/8)
Height (H-2)	178 (7)

► Specification

Voltage (V)	Current (A)	Cycle (Hz)	Continuous Rating (W)		Max. Output(W)
			Input	Output	
110	13.0	50 / 60	1,400	840	1,800
120	12.0	50 / 60	1,400	840	1,800
220	6.7	50 / 60	1,400	840	2,100
230	6.4	50 / 60	1,400	840	2,100
240	6.1	50 / 60	1,400	840	2,100

No load speed : min-1= rpm.	9,000 (for Europe : 10,000)	
Blade size	Diameter : mm (")	125 (5)
	Arbor : mm (")	22.23 (7/8)
Cutting depth : mm (")	0 - 30 (0 - 1-3/16)	
Adjustment of cutting width : mm (")	6(1/4) - 30(1-3/16) Adjustable in 9 stage by inserting the spacers	

► Standard equipment

- * Diamond wheel 125 2 pcs.
- * Plastic carrying case 1 pc.
- * Wrench 35 1 pc.
- * Hex wrench 6 1 pc.

< Note > The standard equipment for the tool shown may differ from country to country.

► Optional accessories

- * Various diamond wheel cutter 125mm
- * Spacer 3mm for adjustment of cutting width
- * Spacer 6mm for adjustment of cutting width

► Features and benefits

SG1250
Electronic features for

- * Soft start for suppressing shock at start
- * Auto cut-off when overloading
- * Speed control

Comfortable gripping by ergonomically designed handle

SJS (Super Joint System)

provides the following benefits.

- * Smooth and comfortable cutting work
- * Suppression of shock by reaction at starting
- * Protection of the mechanical section from the shock by accidental wheel jam

Connectable with vacuum cleaner for dustless work

Aluminum blade case, structured for easy replacement of wheels, and easy adjusting of cutting depth.

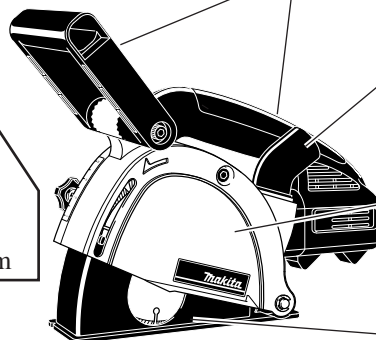

Conveniently located front cover efficiently prevents the dust from spreading, in every cutting depth.

Adjustable groove width in 9 stage by inserting spacers of 3mm(1/8") and 6mm(1/4") in thickness.

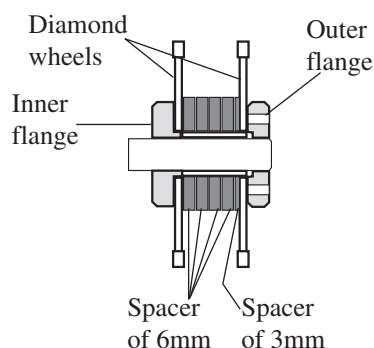

Groove width inc. wheel thickness	Q'ty of 6mm flange	Q'ty of 3mm flange
6mm		1 pc.
9mm	1 pc.	
12mm	1 pc.	1 pc.
15mm	2 pcs.	
18mm	2 pcs.	1 pc.
21mm	3 pcs.	
24mm	3 pcs.	1 pc.
27mm	4 pc.	
30mm	4 pc.	1 pc.

► Comparison of products

Model No.		MAKITA	Competitor A	Competitor B	MAKITA
		SG1250	Model A	Model B	SG150
Specifications		1,400	1,400	1,500	1,800
Power input : W		12	12	N/A	N/A
Rated amperage in USA : A		9,000	8,200	9,500	5,100
No load speed : min-1= rpm.		10,000 (Europe)			
Blade diameter : mm (")		125 (5)	125 (5)	125 (5)	150 (6)
Cutting depth : mm (")		0 - 30 (0 - 1-3/16)	0 - 30 (0 - 1-3/16)	8 - 30 (5/16 - 1-3/16)	7 - 45 (9/32 - 1-3/4)
Possible adjustment of cutting width : mm (")		6(1/4) - 30(1-3/16) in 9 stage	10(3/8), 17(11/16) 23(7/8), 30(1-3/16)	Stepless 15 - 26 (9/16 - 1)	7(9/32) - 35(1-3/8)
Auto cut-off carbon brush		Yes	Yes	Yes	Yes
Electronic for	Overload protection	Yes	Yes	Yes	Yes
	Soft start	Yes	Yes	Yes	Yes
	Speed control	Yes	Yes	Yes	Yes
Torque limiter		Yes (SJS)	Yes	No	No
Connection with vacuum cleaner		Yes	Yes	Yes	Yes
Double insulation		Yes	Yes	Yes	Yes
Vibration : m/s ² (instruction manual)		less than 2.5	5	less than 2.5	(No data)
Sound power level : dB(A) (instruction manual)		86	92	86	(No data)
Cord length : m (ft)		5.0 (16.4)	4.0 (13.1)	4.0 (13.1)	2.5 (8.2)
Dimensions	Length : mm (")	346 (13-5/8)	344 (13-1/2)	358 (14-1/8)	416 (16-3/8)
	Width : mm (")	151 (5-15/16)	164 (6-1/2)	267 (10-1/2)	172 (6-3/4)
	Height : mm (")	178 (7)	248 (9-3/4)	165 (6-1/2)	203 (8)
Net weight : Kg (lbs)	Catalogue	4.1 (9.0)	3.9 (8.6)	3.8 (8.4)	5.6 (12.3)
	Measured	4.13 (9.1)	4.13 (9.1)	4.14 (9.1)	—

< 1 > Lubrication

Apply MAKITA grease SG. No.0 to the following portions designated by black triangle to protect parts and product from unusual abrasion.

Position No.	Parts item	Portion to be lubricated	Amount : g (oz)
(65)	Gear housing	where spiral bevel gear 35 rotates	12 (0.42)

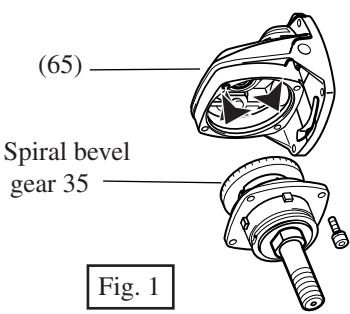
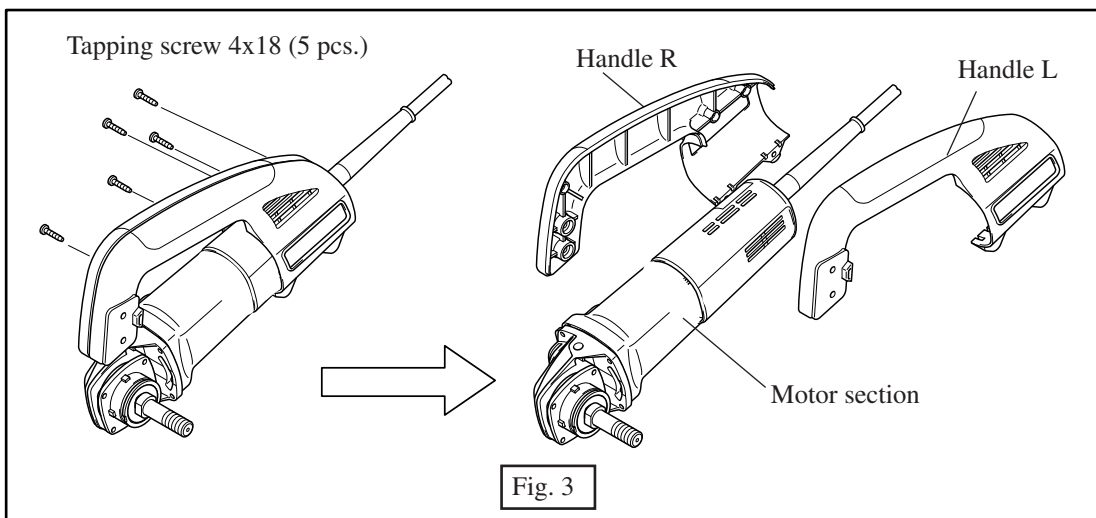
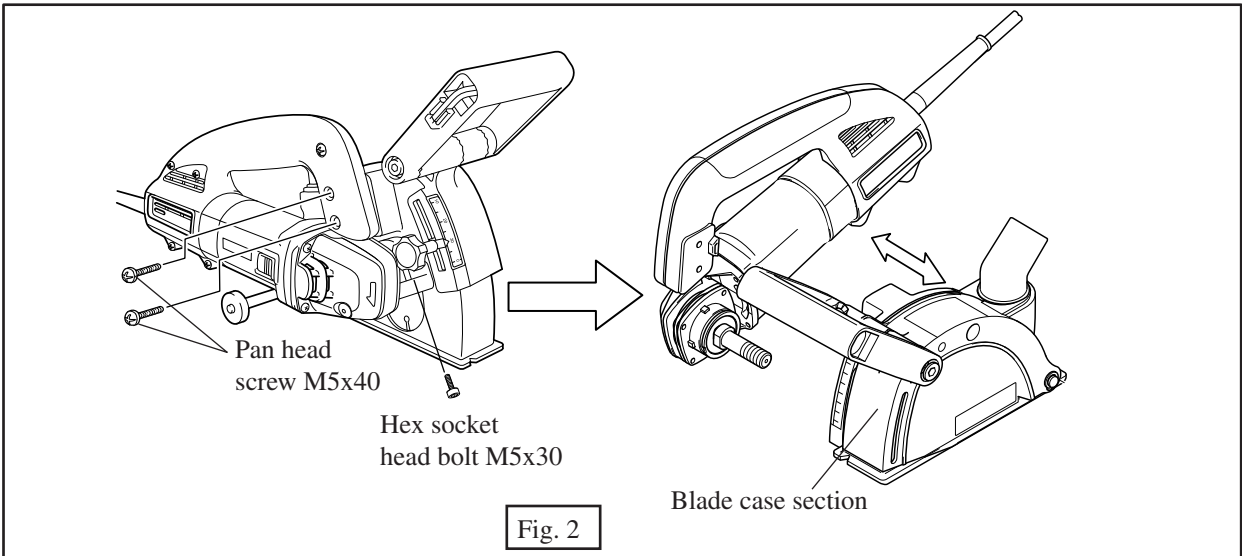

Fig. 1

< 2 > Removing spiral bevel gear 9 and armature

(1) Remove blade case section and handle L and R from the motor section as illustrated in Fig. 2 and Fig. 3.



- (2) Remove gear housing from motor housing. See Fig. 4.
- (3) Separate rear cover by unscrewing tapping screw 4x18. And remove carbon brush. See Fig. 5.
- (4) Remove armature with gear housing cover. See Fig. 6.
- (5) Remove retaining S-6 and flat washer 6 from armature shaft. See Fig. 7.
- (6) Remove spiral bevel gear 9 together with flat washer 12 by employing bearing extractor.
- Remove lock spring 12 by hand, and remove retaining ring S-12 with retaining ring plier. See Fig. 8.
- (7) Remove armature from gear housing cover with gear extractor. See Fig. 9.
- Be careful, not to lose flat washer 12 in this step.

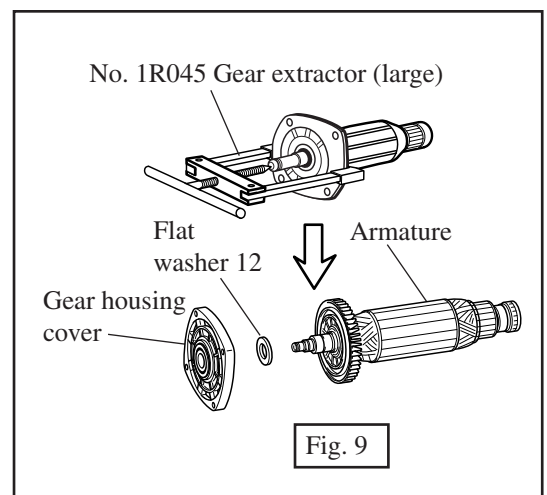
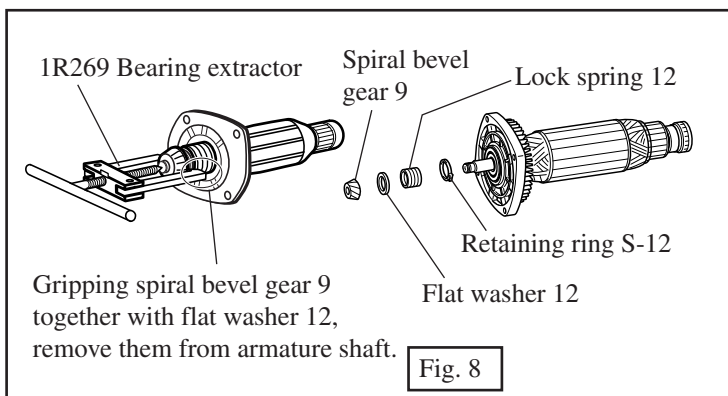
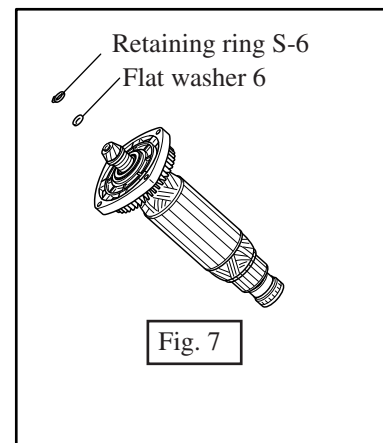
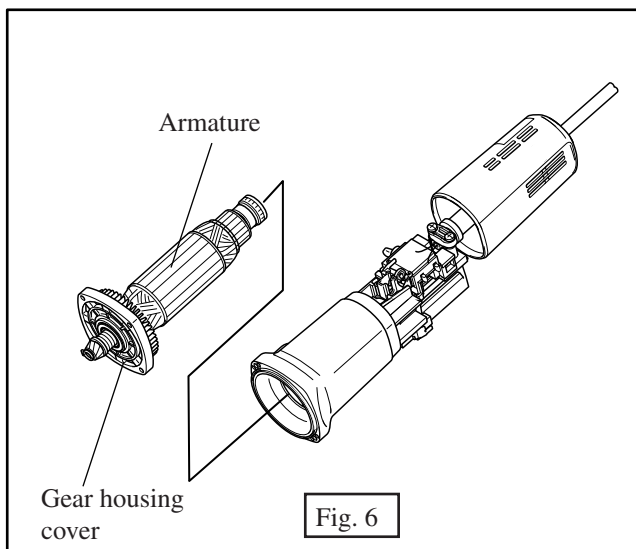
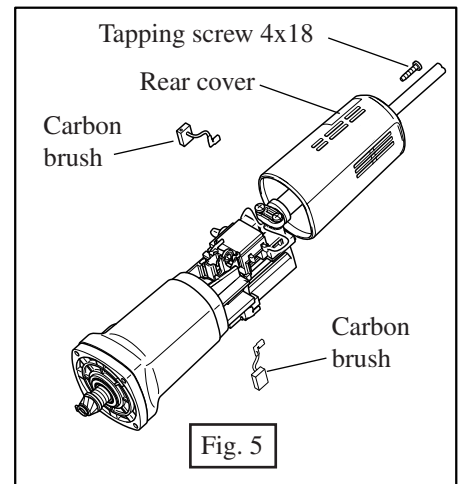
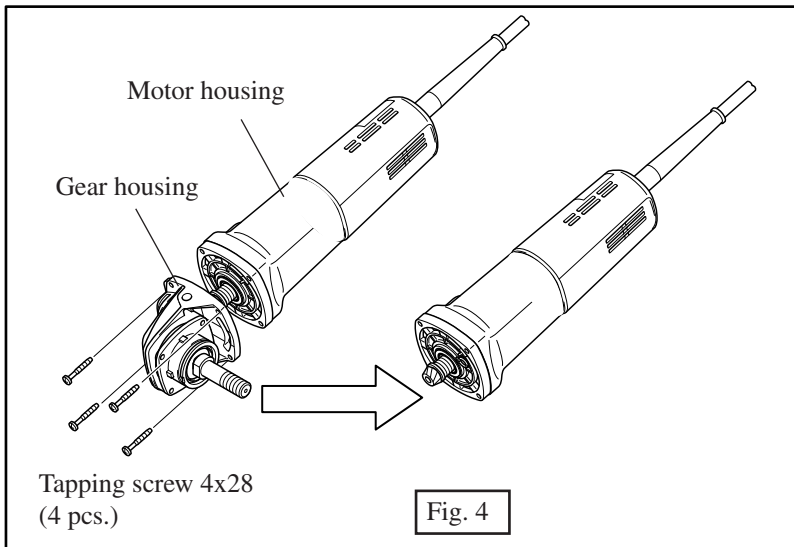

< 3 > Mounting spiral bevel gear 9 and armature

- (1) Mount ball bearing 6001LLB to gear housing cover. See Fig. 10.
- (2) Mount flat washer 12 to the armature shaft. See Fig. 11.
- (3) Mount the armature to gear housing cover with arbor press. See Fig. 12.
- (4) Mount retaining ring S-12, lock spring 12 and flat washer 12 to the armature shaft. See Fig. 13.
- (5) Mount spiral bevel gear 9 to the armature shaft . See Fig. 14.
- (6) Mount flat washer 6 to the armature shaft. And then, secure the parts with retaining ring 6. See Fig. 15.

< Note for replacing spiral bevel gear 9 >

The following parts have to be replaced as a set with the fresh ones.

- * Spiral bevel gear 9
- * Lock spring 12
- * Retaining ring S-6

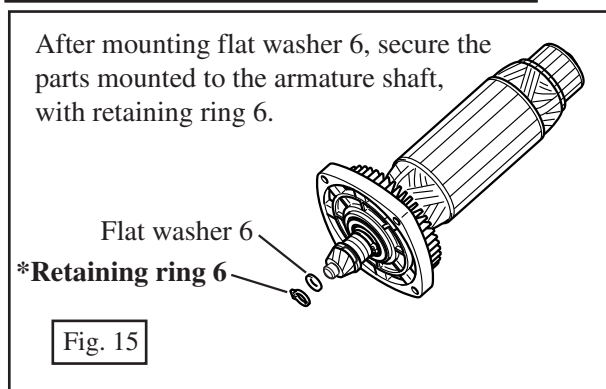
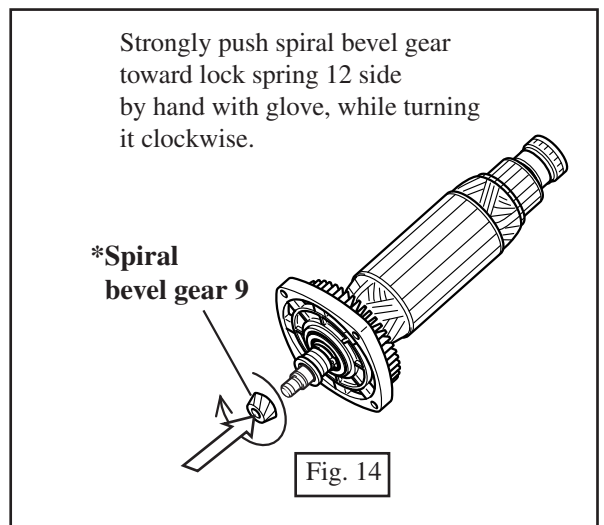
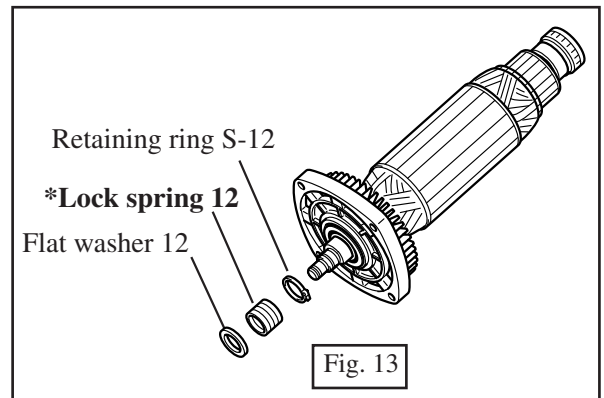
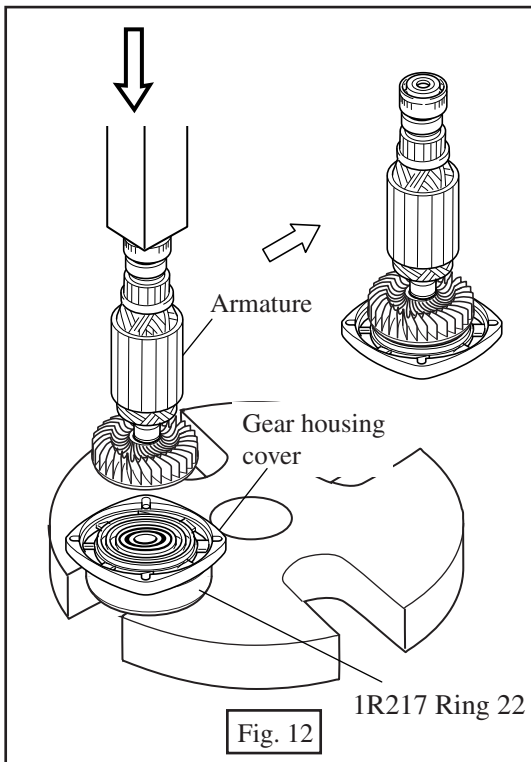
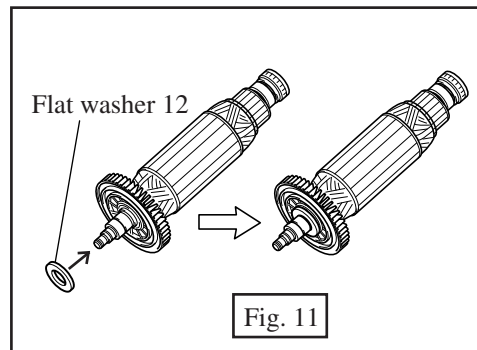
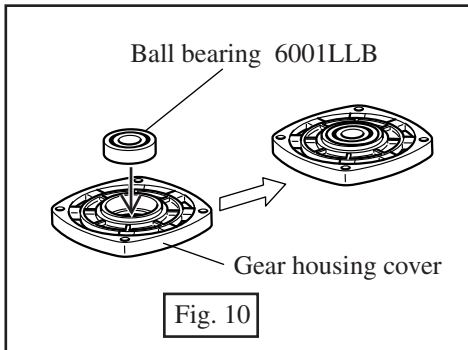

After mounting flat washer 6, secure the parts mounted to the armature shaft, with retaining ring 6.

< 4 > Disassembling gear section

- (1) Unscrew 4 pcs. of hex socket head bolt M4x6. See Fig. 16.
- (2) Remove bearing box. See Fig. 17.
- (3) Remove spindle from helical gear 35 by pressing with arbor press. See Fig. 18.
- (4) Remove bearing retainer with No.1R316 "Adjustable Bearing Retainer Wrench". See Fig. 19.
- (5) Remove ball bearing 6201DDW. See Fig. 20.

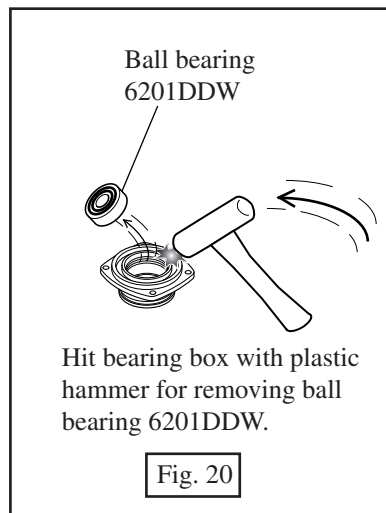
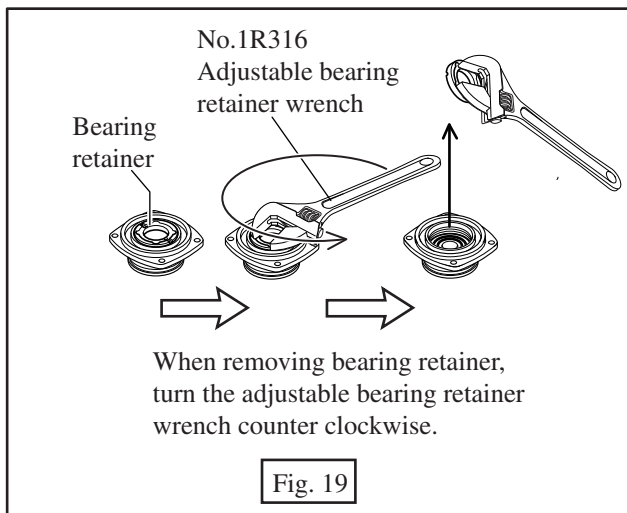
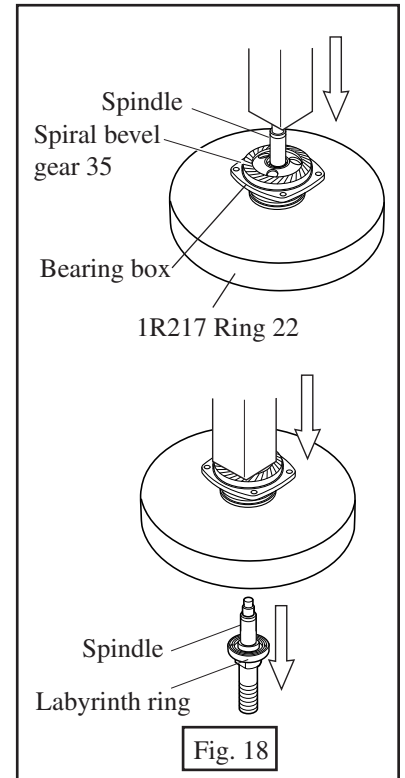
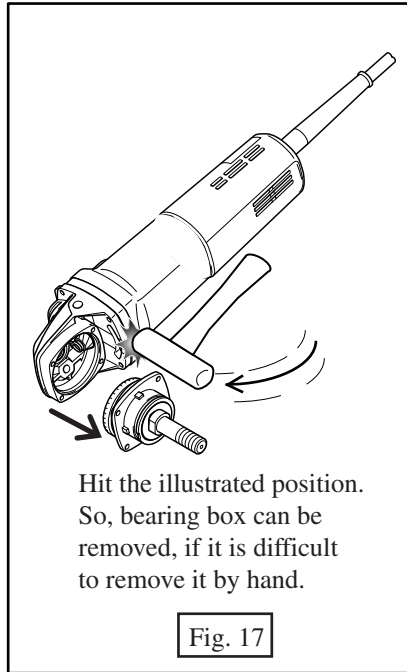
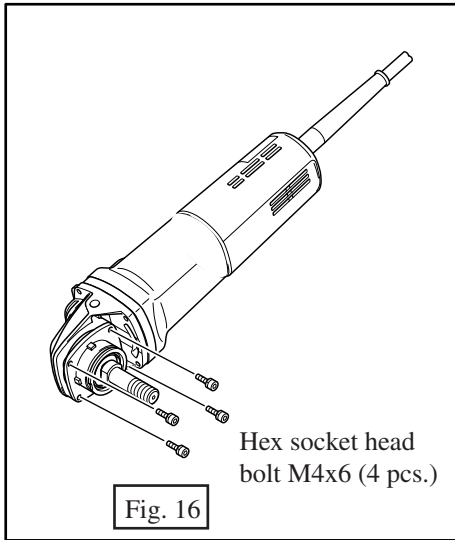

< 5 > Assembling gear section

- (1) Mount ball bearing 6201DDW to bearing box. See Fig. 21.
- (2) Secure the ball bearing 6201DDW by mounting bearing retainer. See Fig. 22.
- (3) Mount labyrinth ring to spindle . See Fig. 23.
- (4) Mount spindle with labyrinth ring and spiral bevel gear 35 to bearing box as illustrated in Fig. 24.

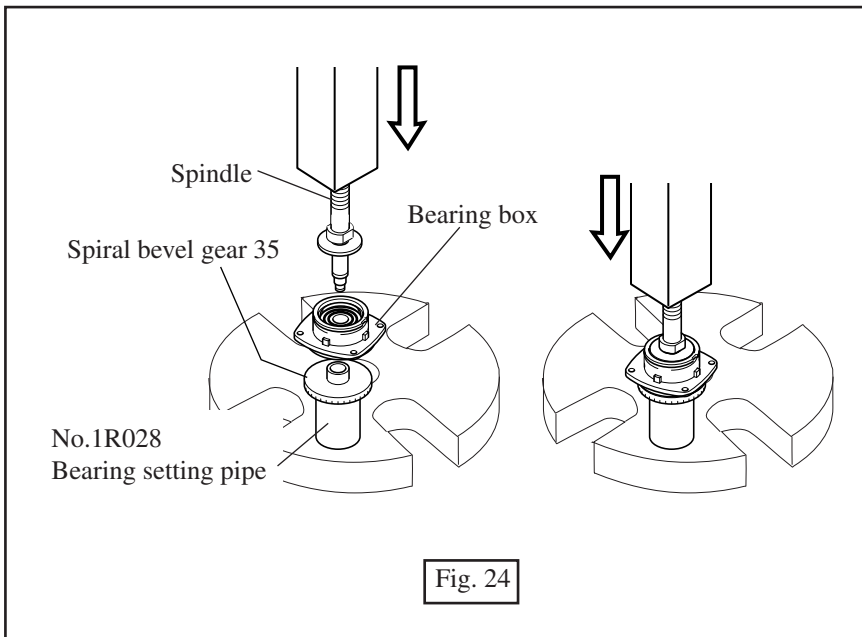
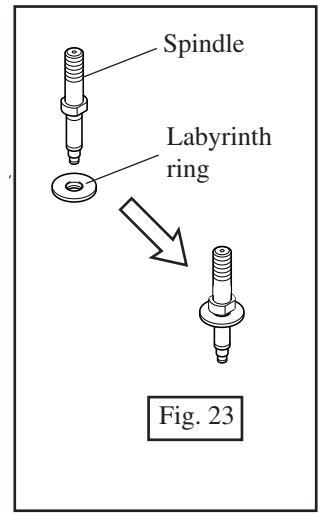
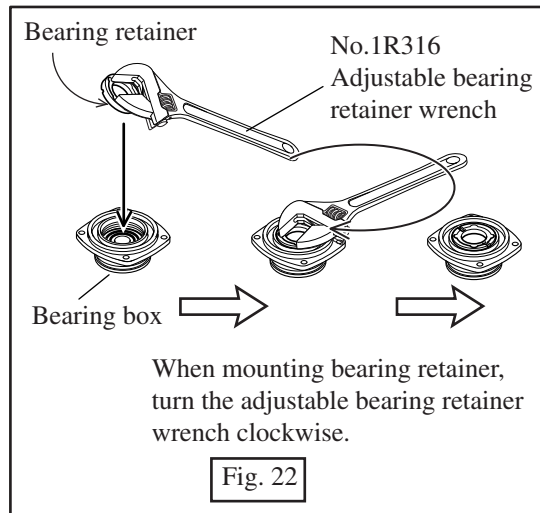
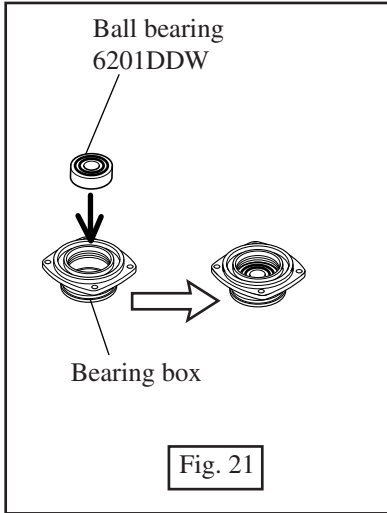

< 6 > Removing shoulder shaft and base

- (1) Remove retaining ring S-10 from shoulder shaft as illustrated in Fig. 25.
- (2) Remove shoulder shaft as illustrated in Fig. 26.
- (3) Now base can be removed from blade case as illustrated in Fig. 27.

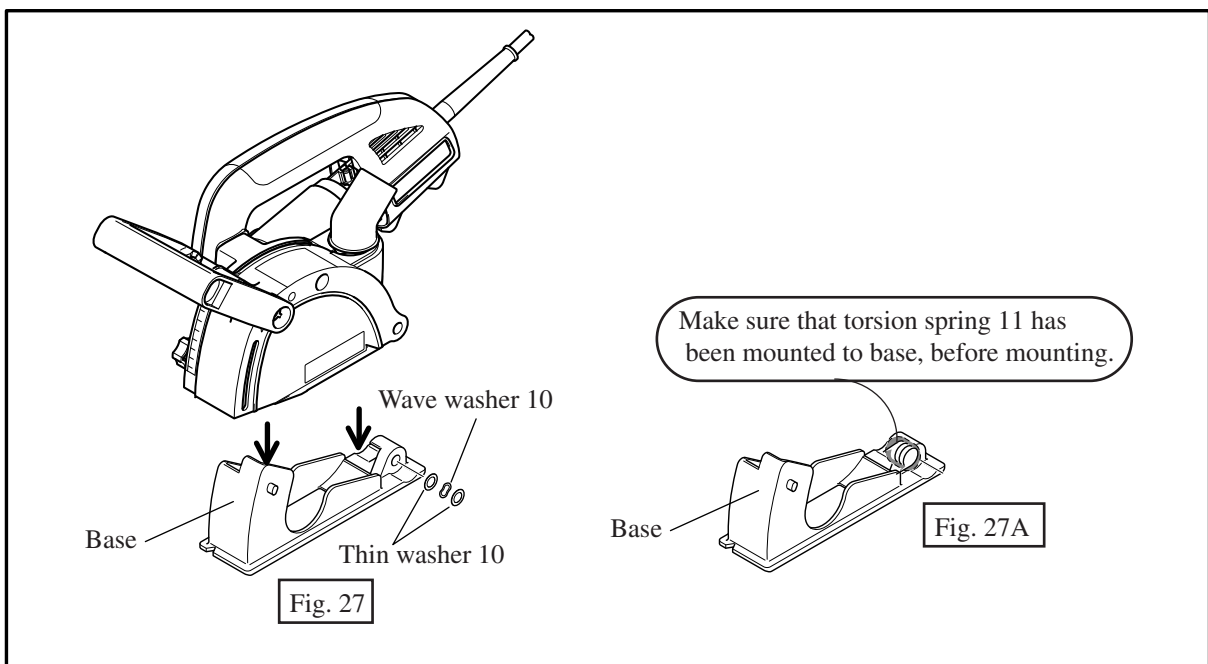
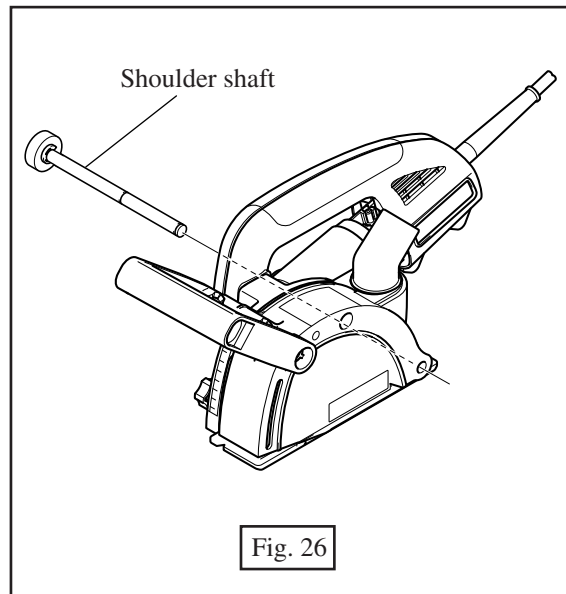
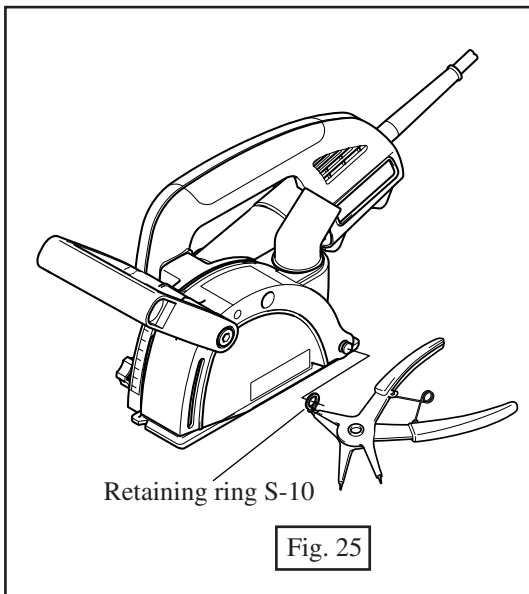

< 7 > Mounting shoulder shaft and base



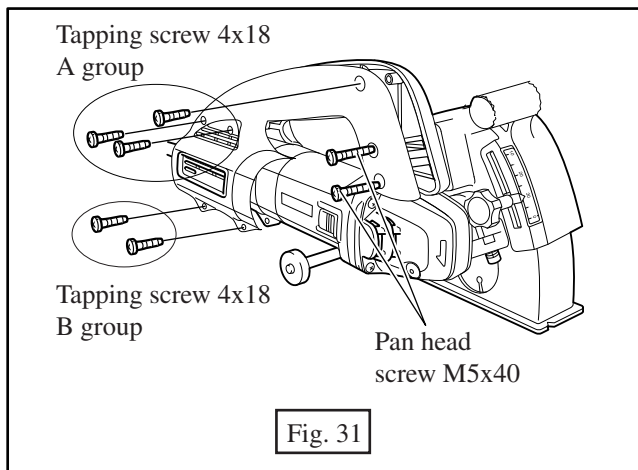
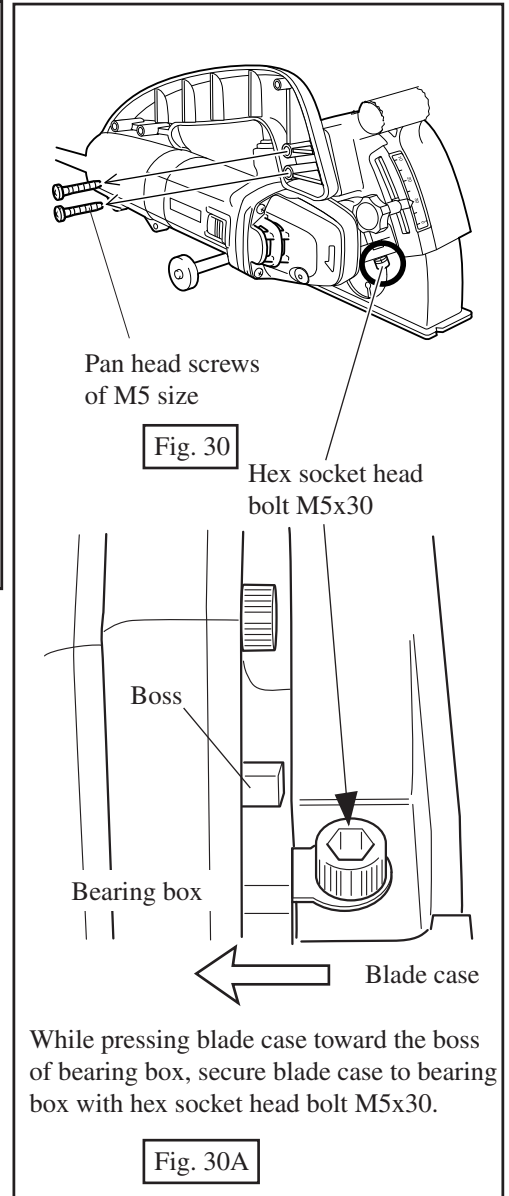
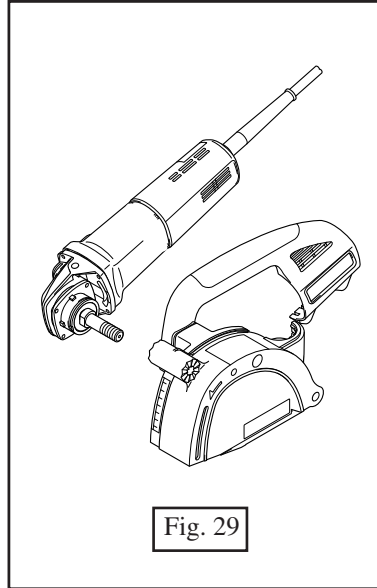
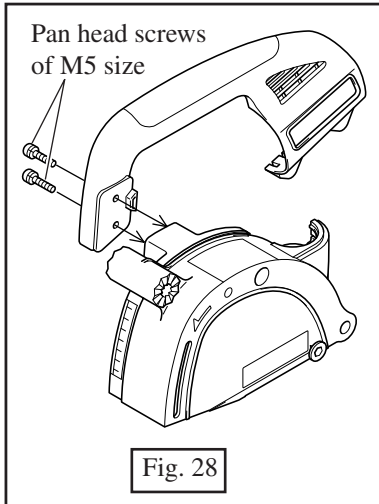

- (1) Take reverse step of the above illustrations, with paying attention to the following matters.
 - * Make sure that torsion spring 11 has been mounted to base. See Fig. 27A.
 - * Mount thin washers and wave washer as illustrated in Fig. 27.

< 8 > Mounting handle

- (1) Secure handle L to blade case with pan head screw of M5 size. See Fig. 28.
The pan head screw of M5 size functions as a pilot screw for the step (3).
- (2) Mount motor section to the handle L. See Fig. 29.
- (3) Secure the motor section to the blade case with hex socket head bolt M5x30, while pressing the blade case toward the boss of bearing box. See Fig. 30 and Fig. 30A. And remove pan head screw of M5 size.
- (4) Mount handle R and secure it with the following order.
 1. Pan head screw M5x40
 2. Tapping screw 4x18 (3 pcs.) of A group
 3. Tapping screw 4x18 (2 pcs.) of B group
 See Fig. 31.



▶ **Circuit diagram**

Color index of lead wires	
Black	
White	
Red	
Blue	

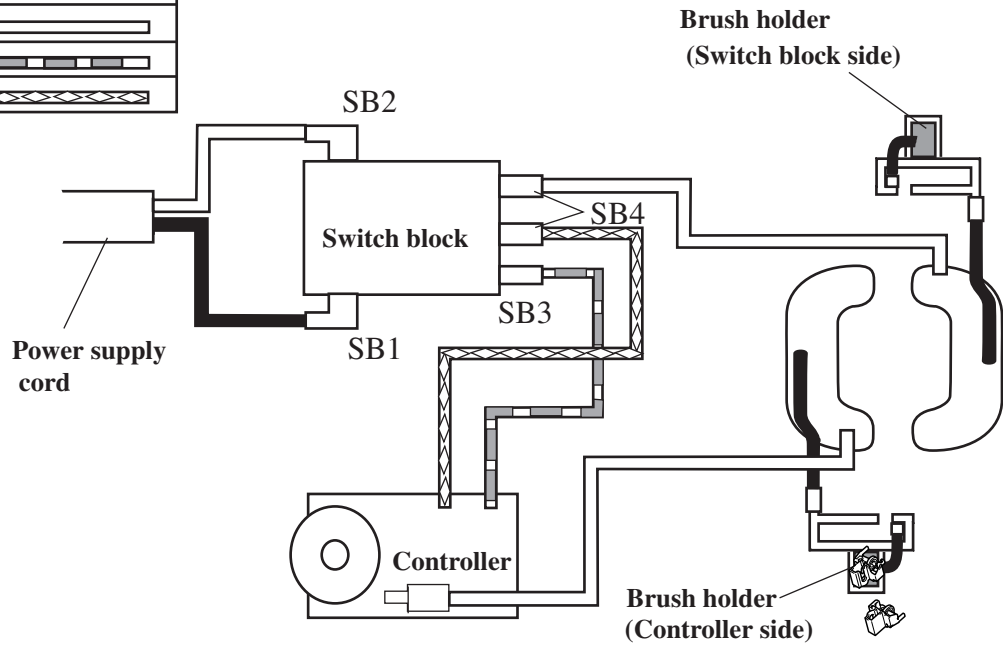
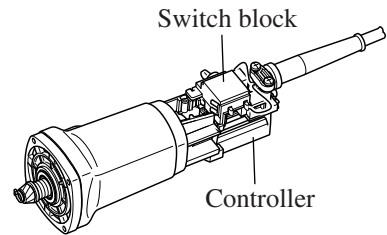

Fig. 32

▶ **Wiring diagram**

< View from controller side >



Put the lead wires of controller in the lead holder so that they are not slacken.

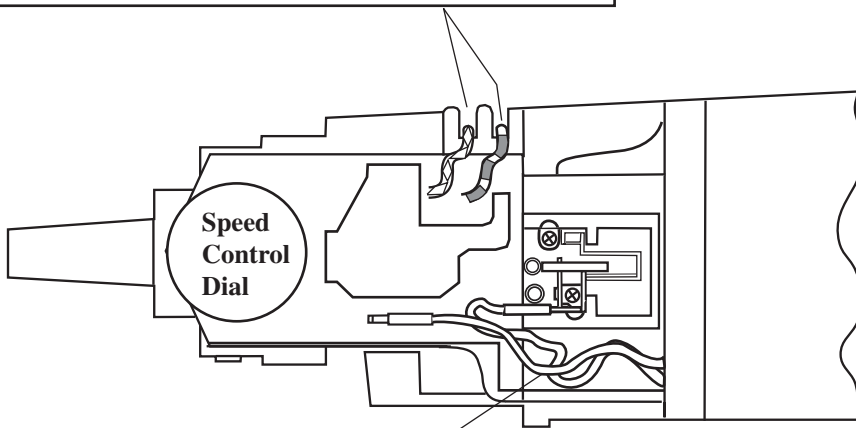

Be careful not to loosen the lead wires of field in motor housing. Put the loosened lead wires in the above place.

Fig. 33

< View from switch block side >

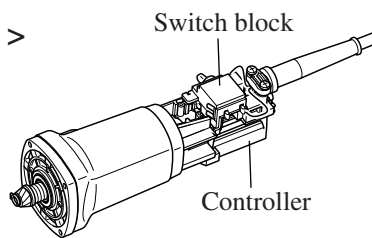

Put lead wires of power supply cord by strain relief as illustrated in Fig. 34.

Do not loosen the lead wires of filed in motor housing. Put the loosened ones in the place as illustrated in Fig.34.

Fix lead wires of controller with lead holder.

Put the slack part of controller's lead wire in the place as illustrated in Fig.34.

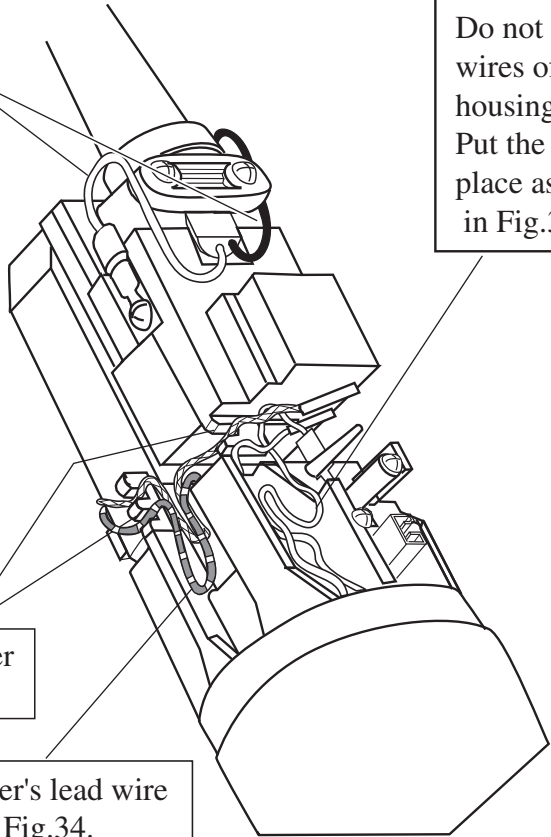

Fig. 34